

RGW40

GUIDED WAVE RADAR

Features

- Unmatched price and performance ratio
- Precise continuous level measurement and reliable point level detection combined in one device
- Fully modular probe design, i.e. the probe types are interchangeable without any special tools or welding
- Complete galvanic isolation on of device electronics from its inputs/outputs and the tank potential (no problems with electrochemical corrosion protection)
- Highly robust measurement due to 4-wire design and innovative signal analysis and disturbance signal suppression

Description

BRIX series RGW40 is a 4-wire TDR-Sensor with single rod or coaxial probe for continuous level measurement and point detection in liquids, with analog and switching output.

Measurement Principle

RGW40 low-energy, high-frequency electromagnetic impulses, generated by the sensor's circuitry, are propagated along the probe which is immersed in the liquid to be measured. When these impulses hit the surface of the liquid, part of the impulse energy is reflected back up the probe to the circuitry which then calculates the fluid level from the time difference between the impulses sent and the impulses reflected. The sensor can output the analyzed level as a continuous measurement reading through its analog output, or it can convert the values into freely positionable switching output signals.



Application Area

The innovative TDR technology enables direct, precise and highly reliable continuous level measurement as well as point level detection in almost every liquid – independent of changing process conditions (such as density, conductivity, temperature, pressure, vapour and turbulence). RGW40 has almost no installation restrictions it can be mounted in small tanks, tall and narrow nozzles and it measures precisely even with difficult tank geometries or close to interfering structures. RGW40 is also especially suitable in bypass chambers and stilling wells. It is suitable for all types of processing and storage applications and has an exceptional performance in liquids with low dielectric constant (i.e. low reflectivity) such as oils and hydrocarbons.

Sensor Components & Probe Type

RGW40 consists of three major components: housing, feed through, and probe. The only components that are exposed to the atmosphere inside the tank are the probe and the part of the feed through below the hexagon. The housing contains the sensor's electronics and input/output terminals and has no contact to the tank atmosphere. The so-called feed through is mounted into the bottom of the housing and serves two main purposes: its outer threaded metal bushing securely connects the sensor to the tank and its inner components guide the high-frequency measurement signal from the electronics through the tank wall into the tank and back. The probe is mounted onto the bottom of the feed through and gets immersed into the liquid inside the tank; the high-frequency measurement signal is propagated along the probe. RGW40 as a flexible modular concept: any probe can be used with any housing since they are joined together by one universal feed through. To meet various application requirements, RGW40 has two different probe types: a single rod probe and a coaxial probe. The single rod probe is suitable for a very wide range of applications and liquids, but the signal has a wider detection radius around the rod. Thus, it is more responsive for measurement signal disturbances which can be easily overcome by observing a few mounting considerations and making simple configuration adjustments to the sensor. The single rod probe is also recommended for installation in bypass chambers and stilling wells, which basically act together with the rod as a big coaxial probe. In the coaxial probe, the high-frequency measurement signal is completely contained within the outer tube. Thus, the coaxial probe is immune against any external conditions and interfering objects outside its tube which could otherwise cause disturbances of the measurement signal. This makes the coaxial probe the ideal solution for a hassle-free 'drop-in anywhere' installation; ensuring reliable measurement under almost any application condition. The concentrated signal within the tube also makes the coaxial probe the ideal choice for measuring low reflectivity liquids (i.e. low dielectric constant) such as oils and hydrocarbons. The coaxial probe is recommended for the use with clean liquids only and cannot be used with viscous, crystallizing, adhesive, coating, or sticky liquids; fibrous liquids, sludge, slurry, pulp; any liquids containing solid particles. Such liquids might cause buildup, bridging or clogging inside the coaxial probe. The probe design of RGW40 is fully modular, i.e. the probe types are interchangeable. The single rod probe actually forms the inner conductor of the coaxial probe: a standard 17,2mm or .7" tube is mounted over the single rod probe and tightened with a very simple, yet safe, ferrule/locknut-style connection; similar to the ones widely used in standard tube fittings.

Sensor Components

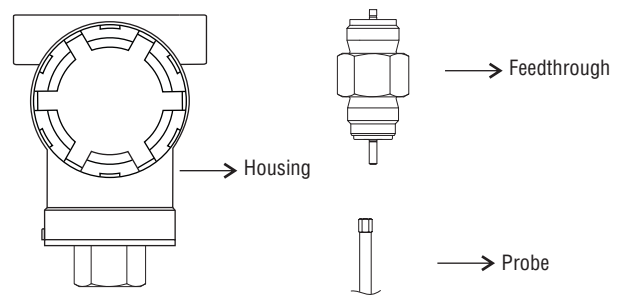

Probe Type Considerations

SINGLE ROD PROBE		
COAXIAL PROBE		
PROBE MOUNTING		
Tall And Narrow Nozzles	+	•
Difficult Tank Or Nozzle Geometries	+	•
Close To Internal Tank Structures Or Tank Wall	+	•
Probe Might Move And Touch Internal Tank Structures Or Tank Wall	+	-
Liquid Spray May Touch Probe Above The Liquid Surface	+	-
Non-stationary Interference Targets, E.g. Agitator Blades	+	-
Measurement Readings At The Very Top Or Bottom Of The Tank	+	•
Non-metallic Tanks	+	•
Bypass Chambers And Stilling Wells	•	+
LIQUID CHARACTERISTICS		
Measuring Low Reflectivity Liquids (i.e. Dielectric Constant)	+	•
Viscous, Crystallizing, Adhesive, Coating, Or Sticky Liquids	-	+
Fibrous Liquids, Sludge, Slurry, Pulp	-	+
Liquids Containing Solid Particles	-	+
Cleanability Of Probe	-	+

- + = Recommended
- = Possible, maybe with configuration and/ or mounting adjustments
- = not recommended

Modular Probe Design

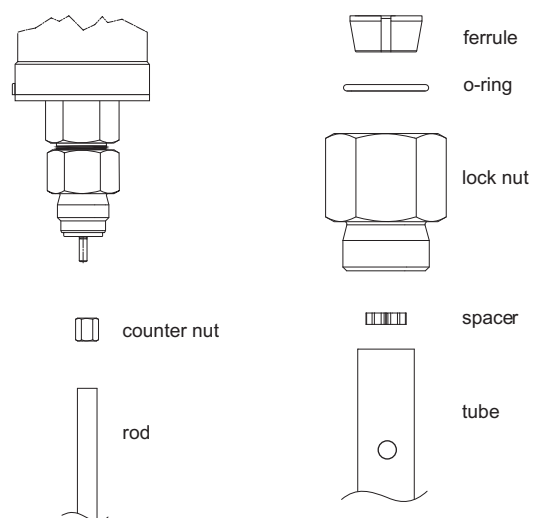

Probe Length And Measuring Range

The reference point for definition of the probe length [L] is always the sealing surface of the connection thread. The probe length [L] is an important mechanical dimension which is needed to make sure the probe physically fits into the tank at the anticipated mounting location; it is not equal to the actual measuring range [M] of the sensor! TDR level sensors have small inactive areas at top [L1] and bottom [L2] of the probe. Those are due to the presence of unavoidable signal disturbances at both ends of the probe. In these inactive areas the measurements are non-linear or have reduced accuracy. Therefore, it is not recommended to actually measure level within those inactive areas. Their length depends on the probe type and the reflectivity (i.e. dielectric constant) of the liquid to be measured. The measuring range [M] of RGW40 extends between the top and bottom inactive areas of the probe; this is the area in which RGW40 will have the specified measurement performance. It is recommended that the maximum and minimum liquid levels to be measured in the tank are actually within the measuring range [M] of the sensor. The span between the lower range value [4mA] and the upper range value [20mA] of the analog current output is equal to 0...100% of your continuous level measurement reading. It is recommended that the span between those two range values stays within the measuring range [M]. The location of the switching point [S] of the switching output can also be freely positioned within the measuring range [M]. Fixed hysteresis or separate upper and lower thresholds can be defined for the switching output.

Probe Length & Measuring Range

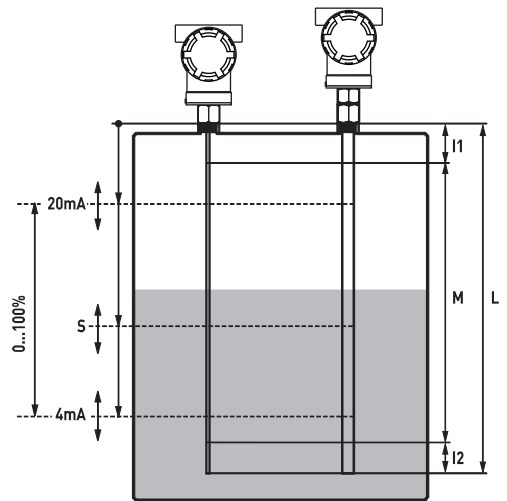

Mounting Details

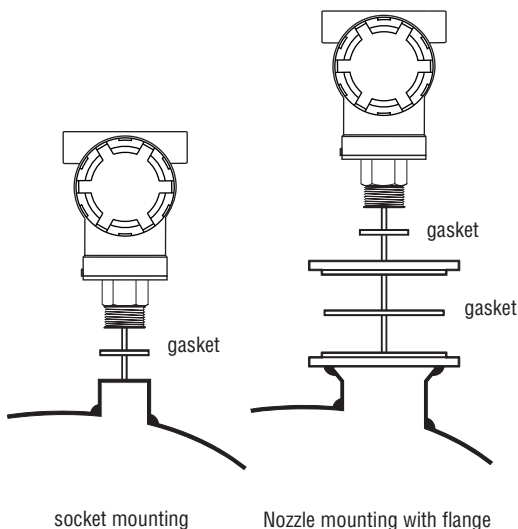

Mounting

RGW40 is mounted vertically to the tank via its connection thread, which is screwed directly into a standard threaded tank connection, i.e. weld-in socket, or it can be screwed into a flange, which is then connected to a tank nozzle. The customer has to ensure proper temperature and pressure ratings for his application and has to select the appropriate seal to connect the sensor (RGW40 comes with a Klingersil C-4400 gasket). RGW40 is very well suited for external mounting into a bypass chamber. Thus, RGW40 is also the ideal replacement for chamber-mounted displacers: simply remove the displacer, keep its existing chamber and fit a RGW40 into it. The powerful disturbance signal suppression features of RGW40 ensures easy retrofitting and reliable measurement in almost any existing displacer chamber. The probes should be installed so that they are not directly impacted by liquids flowing out of the filling inlet. They should neither touch nor sway towards other objects inside the tank or the tank/nozzle walls; e.g. by agitator swirls. In applications with very strong fluid movements, which can also cause excessive lateral force on the probe, it is recommended to fix the probe. The single rod is suitable for a very wide range of applications and liquids, but the signal has a wider detection radius around the rod. Thus, it is more responsive for measurement signal disturbances which can be easily overcome by observing a few mounting considerations and making simple configuration adjustments to the sensor; in most cases it is enough to activate and utilize the powerful disturbance signal suppression features of RGW40.

However, those work most efficiently on stationary interference targets like tall and narrow nozzles or close-by objects. In case that non stationary interference targets close to the single rod probe, like slowly rotating agitator blades, cause problems with the measurement, it is recommended to use the coaxial probe. In any case, the single rod probe should never get in direct contact with the tank/nozzle wall or other objects in the tank. The coaxial probe does not have restrictions regarding mounting position, tank connection, and proximity to the tank wall or other objects inside the tank. The coaxial probe is recommended for installing RGW40 into a non-metallic tank or open pit. If that is not possible, a single rod probe can be used when RGW40 is mounted into at least a DN50 metal flange or screwed into a metal.

Electrical Connection

RGW40 is a 4-wire system: a set of 2 wires for the power supply and separate sets of 2 wires for each output. The wires are connected to the sensor electronic inside the housing via a screwless, cage clamp terminal block for stranded and solid wires 0.5...2mm / AWG 22...14. The housing has two cable entries and can be ordered with assembled standard screw plugs and cable glands. Nevertheless, the customer has to confirm the suitability of those cable glands for his specific application requirements and cabling; and replace them when necessary. IP68-rated screw plugs and cable glands have to be properly mounted (with rubber washers underneath) and have to be properly tightened around cable of suitable type and diameter to ensure the IP68 rating of the housing. RGW40's electronic is galvanically completely isolated from its inputs/outputs and the tank potential; thus avoiding any problems from electrochemical corrosion protection of the tank.

Configuration

Basic configuration of RGW40 can be done directly on the device via a DIP switch, a single push button and visual feedback from an LED. All settings required to get RGW40 fully operational can be performed directly on the device; or RGW40 can be ordered completely pre-configured. For greater convenience, remote configuration, and extensive diagnostics a simple EXCEL spread sheet is provided through which the configuration can be done. A standard HART modem is required for communication between computer and sensor. Communication happens via a digital HART signal that is superimposed onto the analog 4...20mA signal of the current output.

Mounting Considerations

SINGLE ROD PROBE		
COAXIAL PROBE		
Nozzle Diameter	-1	>50mm
Nozzle Height	-	<300mm
Clearance To Tank Wall Or Other Internal Objects	-	>100mm
Clearance Between Probe End And Tank Bottom	-	>2mm
Diameter Of Bypass Chamber / Stilling Well	-2	>25mm

= not recommended

Enough diameter to fit in the coaxial tube (F17,2mm)
 Enough diameter to fit in the coaxial tube (F17,2mm) and enough room around the probe for the liquid to flow in and out of the bypass chamber/ stilling well

Electrical Connection Details

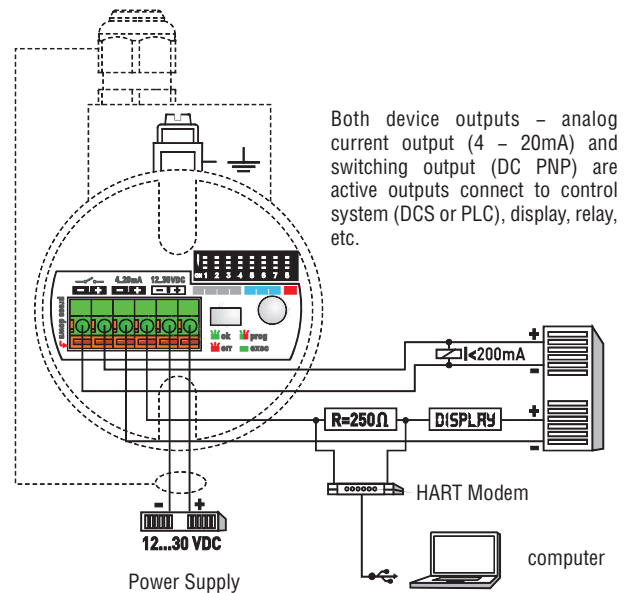

Electrical Specifications	4 wire system
1) Output Function	Continuous level measurement through analog output and point level detection through switching output.
2) Analog output (active)	Current output 4...20 mA the span between the lower range value (4 mA) and the upper range value (20mA) is equal to 0...100% of the contentious level measurement reading. It is recommended that the span between those two range values stays within the measuring range (M)
Total load resistance	<500Ω; HART resistor approx. 250Ω + load resistance approx. 250Ω if the current output is connected to a device with an inner resistance of approx. 250Ω, then there is no additional, external HART resistor necessary. In that case, the HART modem is connected in parallel to the current output wires
Lower range value	4.0mA (span 0%)
Upper range value	20.0mA (span 100%)
Response time	0.5s (default), 2s, 5s (selectable)
Temperature drift	<0,2mm/K change in ambient temperature
3) Switching output DC PNP (active)	NC or NO (short-circuit protected)
Load current	<200mA
Signal voltage HIGH	2V
Signal voltage LOW	0V to 1V
Response time	<100ms
4) Supply Voltage	12 to 30VDC (reverse-polarity protected)
5) Current Consumption	<70mA at 24VDC (no burden)
6) Start-up time	<6s
7) Cable terminals	screwless, cage clamp terminal block for stranded and solid wires 0.5...2mm / AWG 22...14 the usage of cable end sleeves with insulation collar is not recommended

Measurement Specifications	Reference Condition: Dielectric Constant [ϵ_r]=80, water surface, tank F1m, DN200 metal flange
Accuracy	±3mm or 0.03% of measured distance whichever is greatest
Repeatability	<2mm
Resolution	<1mm
Probe type	1) Single rod (Upto 2000mm) 2) Coaxial (Upto 2000mm) 3) Rope Type (Above 2000mm)
Probe length [L]	single rod probe: 100...3.000mm longer length on request coaxial probe: 100...6.000mm can be ordered in 1mm increments the reference point is always the sealing surface of the connection thread (see dimensional drawings)
Inactive area top [L1]	single rod probe, $\epsilon_r=80$: 50mm single rod probe, $\epsilon_r=2$: 80mm coaxial probe, $\epsilon_r=80$: 30mm coaxial probe, $\epsilon_r=2$: 50mm
Inactive areas bottom [L2]	single rod probe, $\epsilon_r=80$: 10mm single rod probe, $\epsilon_r=2$: 50mm coaxial probe, $\epsilon_r=80$: 10mm coaxial probe, $\epsilon_r=2$: 50mm
Measuring range [M]	Probe length [L] less both inactive areas at top and bottom [L1 and L2] in this range EEPL will have the specified measurement performance. It is recommended that the maximum and minimum liquid levels to be measured in the tank are actually within the measuring range [M] of the sensor
Switching point [S]	Freely positionable within the measuring range [M] hysteresis can be set by defining separate upper and lower thresholds; if those are set at the same position, the minimum hysteresis of 3mm applies

Application Specifications	continuous level measurement and point level detection in liquids
Dielectric constant [ε]	single rod probe: >1.8 coaxial probe: >1.4
Conductivity	no restrictions
Density	no restrictions
Dynamic viscosity	single rod probe : <5.000mPa s = 5.000cP coaxial probe : <500mPa s = 500cP
Application temperature	-40°C to +150°C
Ambient temperature	operation: -25°C to +80°C storage: -40°C to +85°C
Application pressure	-1bar to 40bar
Velocity of level change	<1.000mm/s
Interface (e.g. oil on top of water)	an oil layer of <70mm thickness on top of water is not detected by the sensor; in this case the sensor will detect only the water level at a slightly lower position than actual. From an oil layer thickness >70mm onwards, the sensor detects the total level, including the oil layer, according to specifications

Mechanical Specifications	
Material expose to tank atmosphere	single rod probe : 1.4404 / 316L and PEEK coaxial probe : 1.4404 / 316L, PEEK and o-ring seal: EPDM or FKM (Viton) other o-ring materials on request gasket at connection thread : Klingersil C-4400, 2mm thick
Conductivity	no restrictions
Density	no restrictions
Dynamic viscosity	single rod probe : <5.000mPa s = 5.000cP coaxial probe : <500mPa s = 500cP
Application temperature	-40°C to +150°C
Ambient temperature	operation: -25°C to +80°C storage: -40°C to +85°C
Application pressure	-1bar to 40bar
Velocity of level change	<1.000mm/s
Interface (e.g. oil on top of water)	an oil layer of <70mm thickness on top of water is not detected by the sensor; in this case the sensor will detect only the water level at a slightly lower position than actual. From an oil layer thickness >70mm onwards, the sensor detects the total level, including the oil layer, according to specifications
Material housing	CMRI Certified, Flame Proof, die Cast Aluminium Lm6, Housing 1) without Display: 100 mm (H) X 102 mm (W) 2) with Display: 130 mm (H) X 220 mm (W) X 190 mm (D)
Housing rating	IP-66
Cable entries /Cable gland	M20 x 1.5 Pitch (F)
Connection thread [CT]	G...A (wrench size 32mm) other connection threads on request

Dimensional & Mounting Panel

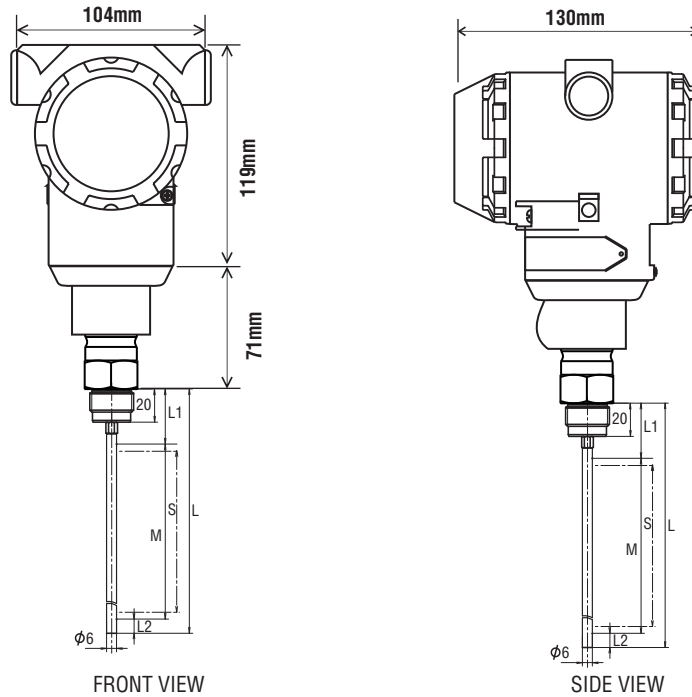

L = Probe Length
 L1 = Inactive Area Top
 L2 = Inactive Area Bottom
 M = Measuring Range
 S = Span
 DIMENSIONS IN MM

Ordering Information

Sample Order Code :

A2	C1	D2	E1	F2	G1	H2	M3	O7	P3
----	----	----	----	----	----	----	----	----	----

Parameter	Code	Description	Parameter	Code	Description														
A	Measuring Range	A2	600 mm	F	F1	M 20 x 1.5 (F)													
		A3	1000 mm		F2	1/2" NPT (F)													
		A4	2000 mm	G	G1	With Local Indicator													
		A5	3000 mm		G2	Without Local Indicator													
		A6	6000 mm	H	H1	4 to 20 mA													
		A7	12000 mm		H2	4 to 20 mA with HART													
		A8	15000 mm	M	M2	1 1/2" BSP (M)													
		C	Electronics Area Classification		C1	Field Mount Weather Proof IP67	M3	2" BSP (M)											
C2	Flameproof (CMRI IIA IIB Certified)				M4	2" PVC Flanged													
D	Power Supply	D2	24V DC (+/- 10%)		M5	2" SS316 Flanged													
			D5		24V DC Two Wire Loop Powered	M6	50 NB SS316 Tri Clover												
E	MOC Electronics Enclosure	E1	Die Cast Aluminium		MY	Other													
			E2	SS316	O	O7	SS316												
Note :	Due to our continuous product revisions, design specification and model numbers are subject to change without notice. Accuracy defined at Lab Conditions. For other requirement please consult factory.			O8		PTFE Lined													
									O9	Hastelloy C									
												OX	NA						
																P	Probe Type	P3	Single Rod (Upto 2000 mm)
																		P4	Coaxial (Upto 2000 mm)
P5	Rope Type (Above 2000 mm)																		
PX	NA																		